

Specification Sheet

FX122G3 Combistar



Product Description:

- The Angelo Po CombiStar FX is a versatile and advanced cooking system designed to meet the demands of commercial kitchens. With its programmable controls and touch display, this oven allows for precise and efficient cooking.

Cooking Programs:

- 150 cooking programs with 18 steps each
- 76 program automatic clever cooking icon files
- Favorites menu
- Special cooking techniques programs: Holding, Delta T, Low Temperature Cooking, Rethermalization, HACCP Control Management, Hot and Cold Smoking, Vacuum Cooking, Drying, and Advanced Cook & Chill Interface Technology.

Capacity

- (24) 12"X20" Hotel Pan
- (12) 18"X26" Full Size Sheet Pans
- 253 Quarts (240 l) - 308 lb (140Kg) Max
- Wide range of accessories for various cooking processes such as grilling, braising or baking

Convection Heat

- 50°F - 572°F (10°C - 300°C)
- 0% - 100% Humidity

Steam

- 86°F - 257°F (30°C - 125°C)

Combination

- 6°F - 482°F (30°C - 250°C)
- 0% - 90% Humidity

Technology and Features:

- USB interface for easy program transfer and updates
- AISI 316L marine grade stainless steel cavity for durability and easy cleaning
- EHO ergonomic hands-free door handle for safe and easy access
- DCR humidity control and management sensor for optimal cooking results
- Auto reverse 5-speed fan and 1 static mode for even cooking and baking
- PDP progressive density 5 point multi-sensor probe for accurate temperature control
- TAS fully automatic self-cleaning washing system for effortless maintenance
- ADC patented drain cleaning system for easy and efficient cleaning
- WDC descale warning indicator for timely maintenance
- APM automatic power management for energy efficiency
- MCF steam cloud escape reduction for a safe and comfortable working environment
- User manual onboard icon for quick reference and troubleshooting
- RDC & EVOS boilerless and efficient steam generation system for efficient and eco-friendly operation
- EVC color graphic shatterproof control display panel for easy navigation and control
- EASYSTAR film & video capability for sharing recipes and tutorials
- Eco Function to reduce energy and water consumption for sustainable cooking.



Specification Sheet - FX122G3 Combistar



Model	FX122G3T Combistar™
Net Dimensions (WxDxH)	46.4"x42.9"x47" (117.8x109x119.5 cm)
Shipping Dimensions (WxDxH)	52"x44.9"x55.9" (132x114x142 cm)
Interior Dimensions (WxDxH)	35-3/64" x 32-31/64" x 36-13/32" (890 x 825 x 925 mm)
Net Weight	573 lb (260 kg)
Shipping Weight	661 lb (300 kg)
Full size (20"x12"x2-1/2") pan Capacity	twenty-four (24)
2/1 GN (650x530x65mm) pan Capacity	twelve (12)
Product Capacity	253 Quarts (240 l) - 308 lb (140Kg) Max
Gas Power	115,000 BTU (33,7kW) Nat and LPG
Max Connected Pressure NG	10.5" WC
Min Connected Pressure NG	3.5" WC
Max Connected Pressure LPG	13" WC
Min Connected Pressure LPG	8" WC
Hook Up	3/4" NPT
Notes	Ovens can be converted between NG and LPG. Cannot work on any GFI outlet or breaker.
Electric Power	0.96 kW
Voltage	120V
Phase	1ph N
Amperes	11.5A
Cycle/Hz	60 Hz
AWG	AWG12
WATER INLET (Drinking, Cold Water)	Inlet: 3/4" - Line Pressure: 30 to 60 psi (2 to 4 bar)
Required Chlorine	< 0.1 ppm (mg/l)
Required Chlorides	< 30 ppm (mg/l)
Required Sulphates	< 30 ppm (mg/l)
Recommended Iron	< 0.1 ppm (mg/l)
Recommended Copper	< 0.05ppm (mg/l)
Recommended Manganese	< 0.05pp
Hardness	3 to 9°f (1,5 to 5 °d; 2,1 to 6,3 °e; 30 to 90 ppm)
Langelier Index	> 0,5
TDS	40 to 150 ppm
Flow Rate	4.6 gallons/hour
pH	7 to 8.5
Water Outlet	1-1/4" Drain with Air Gap
Installation Requirements	Hood Installation is Required for Cooking Smoke. The Oven Must Be Installed Level. Install Water Supply Shut-Off Valve and Back-Flow Preventer
Left side of equipment	20" from heat source and 19" recommended for service access. Min. clearance 6-1/2" - When left side clearance is less than 20" from a heat source, inquire about a heat shield
Right	Min. clearance 3-57/64"
Top	Min. clearance 12"
Bottom	Min. clearance 4" (also in the Counter Top installations)
Back	20" from heat cooking equipment (oven in the middle of the room) - Min. clearance 4"

It is highly recommended that the Angelo Po reverse osmosis water treatment systems, as well as Angelo Po brand cleaning chemicals (CL55XL detergent and BR55XL brightener) be used and incorporated into all Angelo Po Combistar combi oven installations.

It is the sole responsibility of the owner / operator / purchaser of the Angelo Po equipment, to verify that the incoming water supply is comprehensively tested to meet the Angelo Po water compliance standards, published in this document.

Non-compliance with the Angelo Po water standards noted herein could potentially damage the equipment and/or VOID the original manufacturer's standard warranty.

Specification Sheet

FX122G3 Combistar

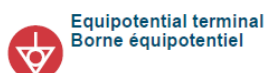
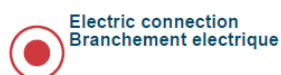
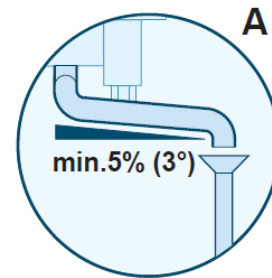
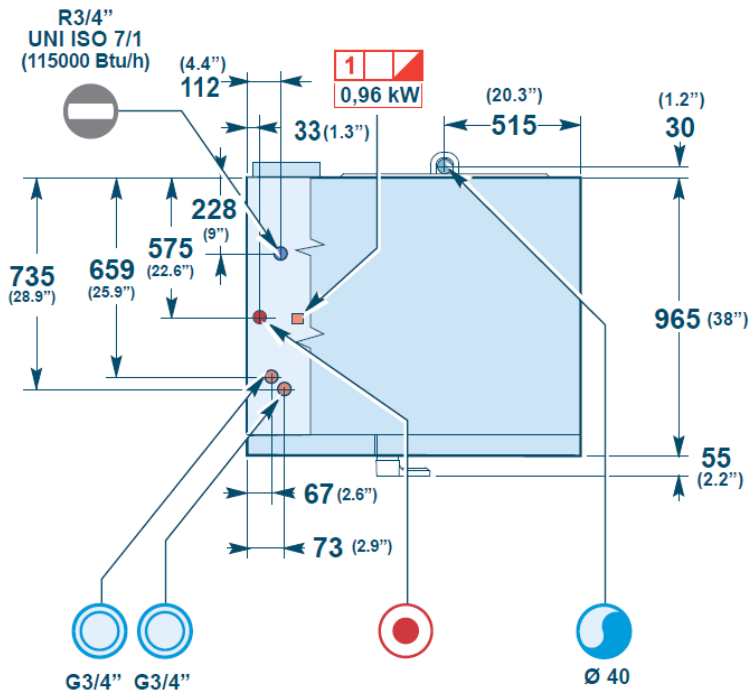
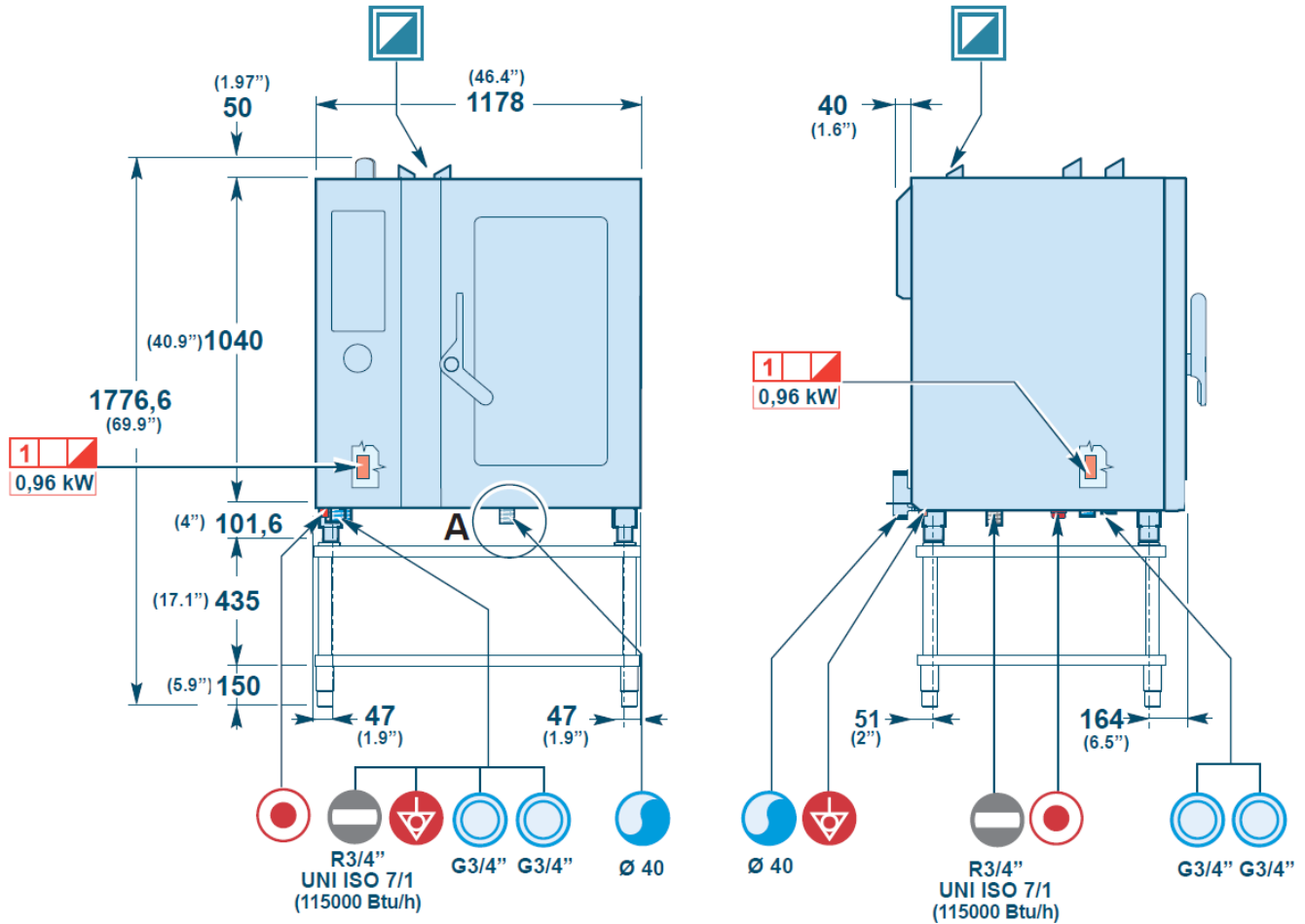

Unit of measurement = mm / in
Unité de mesure = mm / in