

Specification Sheet

FX201G3 Combistar



Product Description:

- The Angelo Po CombiStar FX is a versatile and advanced cooking system designed to meet the demands of commercial kitchens. With its programmable controls and touch display, this oven allows for precise and efficient cooking.

Cooking Programs:

- 150 cooking programs with 18 steps each
- 76 program automatic clever cooking icon files
- Favorites menu
- Special cooking techniques programs: Holding, Delta T, Low Temperature Cooking, Rethermalization, HACCP Control Management, Hot and Cold Smoking, Vacuum Cooking, Drying, and Advanced Cook & Chill Interface Technology.

Technology and Features:

- USB interface for easy program transfer and updates
- AISI 316L marine grade stainless steel cavity for durability and easy cleaning
- EHO ergonomic hands-free door handle for safe and easy access
- DCR humidity control and management sensor for optimal cooking results
- Auto reverse 5-speed fan and 1 static mode for even cooking and baking
- PDP progressive density 5 point multi-sensor probe for accurate temperature control
- TAS fully automatic self-cleaning washing system for effortless maintenance
- ADC patented drain cleaning system for easy and efficient cleaning
- WDC descale warning indicator for timely maintenance
- APM automatic power management for energy efficiency
- MCF steam cloud escape reduction for a safe and comfortable working environment
- User manual onboard icon for quick reference and troubleshooting
- RDC & EVOS boilerless and efficient steam generation system for efficient and eco-friendly operation
- EVC color graphic shatterproof control display panel for easy navigation and control
- EASYSTAR film & video capability for sharing recipes and tutorials
- Eco Function to reduce energy and water consumption for sustainable cooking.

Capacity

- (20) 12"X20" Hotel Pan
- 213 Quarts (202 l) - 253 lb (115 Kg) Max
- Wide range of accessories for various cooking processes such as grilling, braising or baking

Convection Heat

- 50°F - 572°F (10°C - 300°C)
- 0% - 100% Humidity

Steam

- 86°F - 257°F (30°C - 125°C)

Combination

- 6°F - 482°F (30°C - 250°C)
- 0% - 90% Humidity



Specification Sheet - FX201G3 Combistar



Model	FX201G3 Combistar™
Net Dimensions	WxDxH 36,6"x36,1"x73" (92,9x91,6x185,5 cm)
Shipping Dimensions	WxDxH 41,3"x40,2"x85,6" (104,8x102x217,3 cm)
Interior Dimensions	WxDxH 25-25/64" x 25-19/32" x 57-1/4" (645 x 650 x 1454 mm)
Net Weight	752 lb (341 kg)
Shipping Weight	829 lb (376 kg)
Full size (20"x12"x2-1/2") pan Capacity	twenty (20)
Half size sheet (18"x13"x1") pan Capacity	twenty (20) on wire shelves only (additional wire shelves required for max capacity)
Product Capacity	213 Quarts (202 l) - 253 lb (115 Kg) Max
Gas Power	145,000 BTU (42,5kW) Natural Gas 13,5000 BTU (39,6kW) LPG
Max Connected Pressure NG	10.5" WC
Min Connected Pressure NG	3.5" WC
Max Connected Pressure LPG	13" WC
Min Connected Pressure LPG	8" WC
Hook Up	3/4" NPT
Electric Power	1,295 kW
Voltage	120V
Phase	1ph N
Amperes	15,1 A
Cycle/Hz	60 Hz
AWG	AWG12
Notes	Oven cannot work on any GFI outlet or breaker
WATER INLET (Drinking, Cold Water)	Inlet: 3/4" , Line Pressure: 30 to 60 psi (2 to 4 bar)
Required Chlorine	< 0,1 ppm (mg/l)
Required Chlorides	< 30 ppm (mg/l)
Required Sulphates	< 30 ppm (mg/l)
Recommended Iron	< 0,1 ppm (mg/l)
Recommended Copper	< 0,05ppm (mg/l)
Recommended Manganese	< 0,05ppm(mg/l)
Hardness	3 to 9°f (1,5 to 5 °d; 2,1 to 6,3 °e; 30 to 90 ppm)
Langelier Index	> 0,5
TDS	40 to 150 ppm
Flow Rate	4.6 Gallons / h
pH	7 to 8.5
WATER OUTLET	1-1/4" Drain with Air Gap
INSTALLATION REQUIREMENTS	Hood Installation is Required for Cooking Smoke, The Oven Must Be Installed Level, Install Water Supply Shut-Off Valve and Back-Flow Preventer
Left side of equipment	20" from heat source and 19" recommended for service access. Min clearance 6-1/2" - When left side clearance is less than 20" from a heat source, inquire about a heat shield.
Right	Min. clearance 3-57/64"
Top	Min. clearance 12"
Bottom	Min. clearance 4" (also in the Counter Top installations)
Back	20" from heat cooking equipment (oven in the middle of the room) - Min. clearance 4"

It is highly recommended that the Angelo Po reverse osmosis water treatment systems, as well as Angelo Po brand cleaning chemicals (CL55XL detergent and BR55XL brightener) be used and incorporated into all Angelo Po Combistar combi oven installations.

It is the sole responsibility of the owner / operator / purchaser of the Angelo Po equipment, to verify that the incoming water supply is comprehensively tested to meet the Angelo Po water compliance standards, published in this document.

Non-compliance with the Angelo Po water standards noted herein could potentially damage the equipment and/or VOID the original manufacturer's standard warranty.

Specification Sheet

FX201G3 Combistar

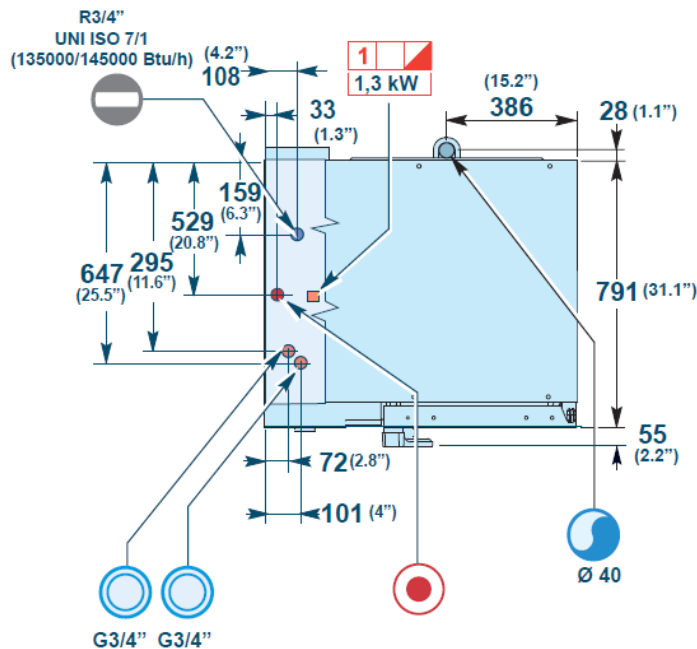
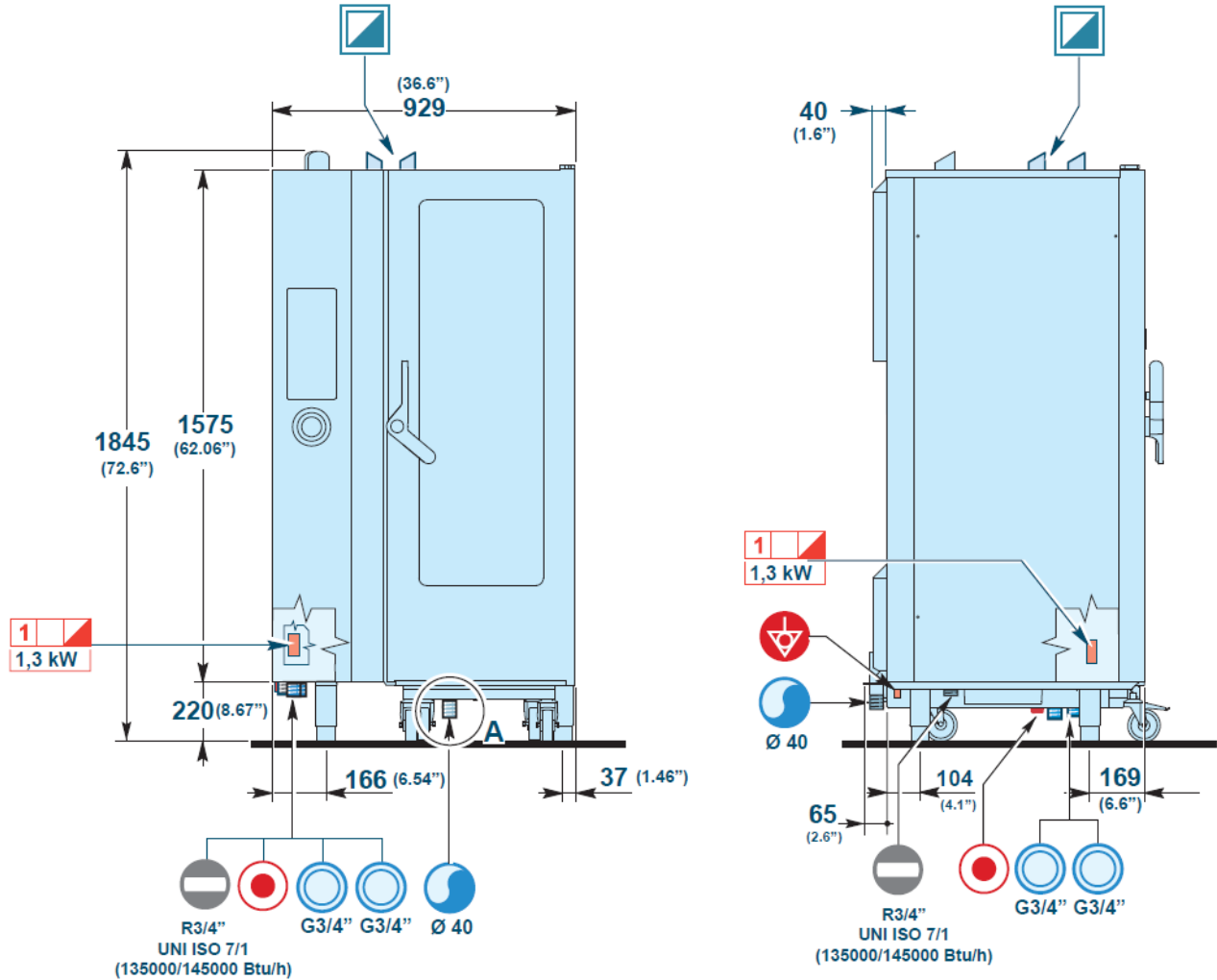

-  Gas input
Entrée Gas
-  Cold water input
Entrée eau froide
-  Electric connection
Branchement électrique
-  Terminal board
Plaque à bornes
1~ N ⊥
120 V
-  Flue gas drain
Degagement gas brules
-  Water drain
Vidage eau
-  Equipotential terminal
Borne équipotentiel
- Unit of measurement = mm / in
Unité de mesure = mm / in